

NOTES: UNLESS OTHERWISE SPECIFIED

REVISIONS				
ZONE	REV.	DESCRIPTION	DATE	APPROVED
	XB		4/26/2007	
	XC	UPDATED MOUNTING HOLES	6/6/2007	J. GRAY
	XD	200396-01 REPLACED WITH 200396-02.	8/5/2008	B. TWEHUES

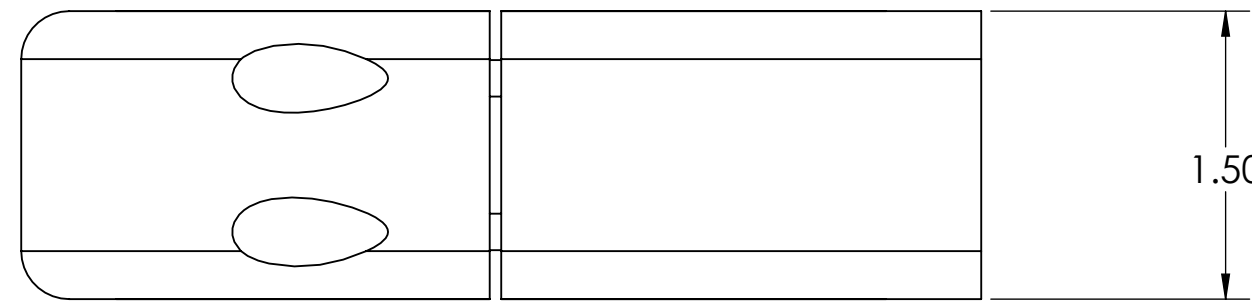
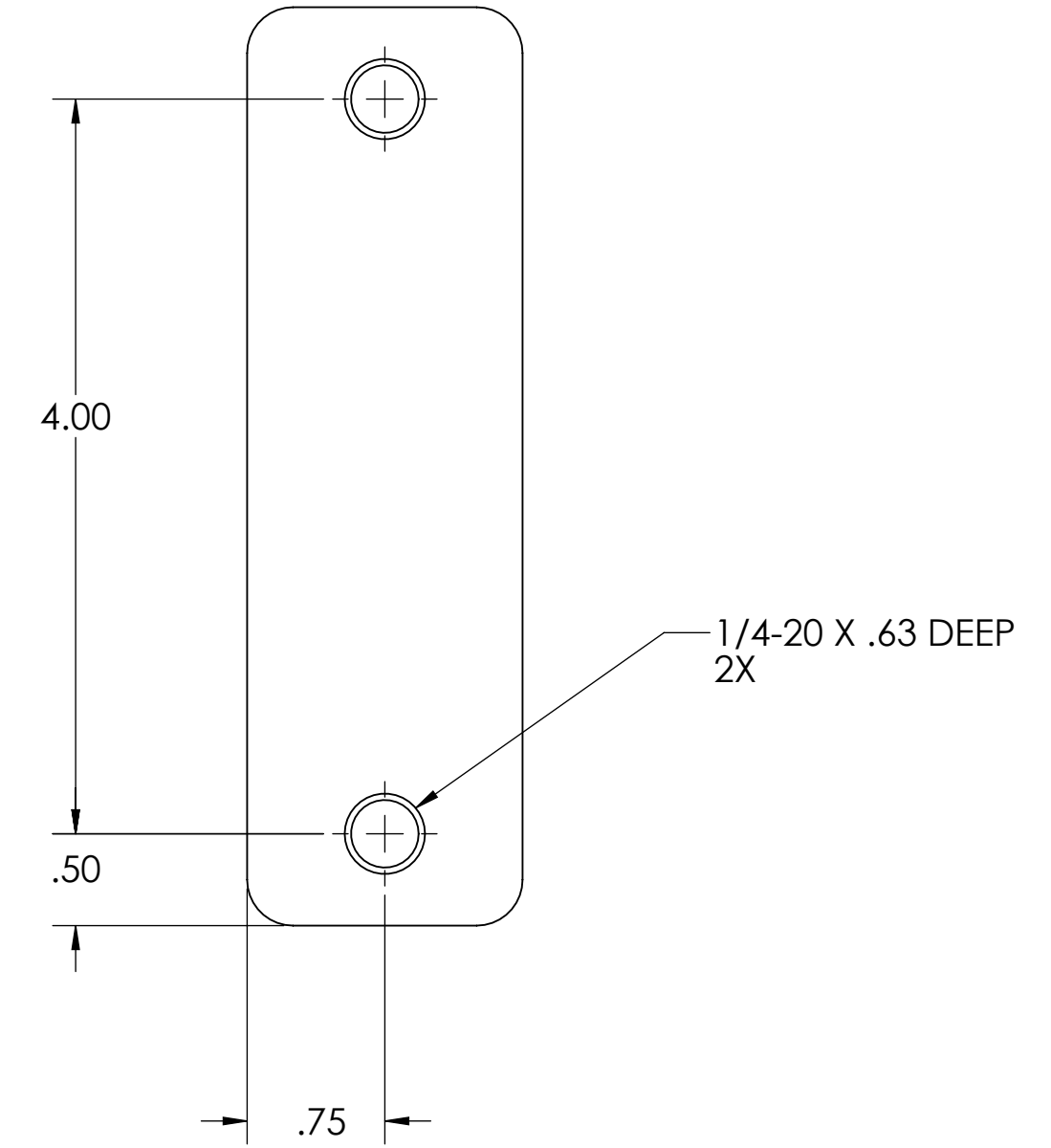
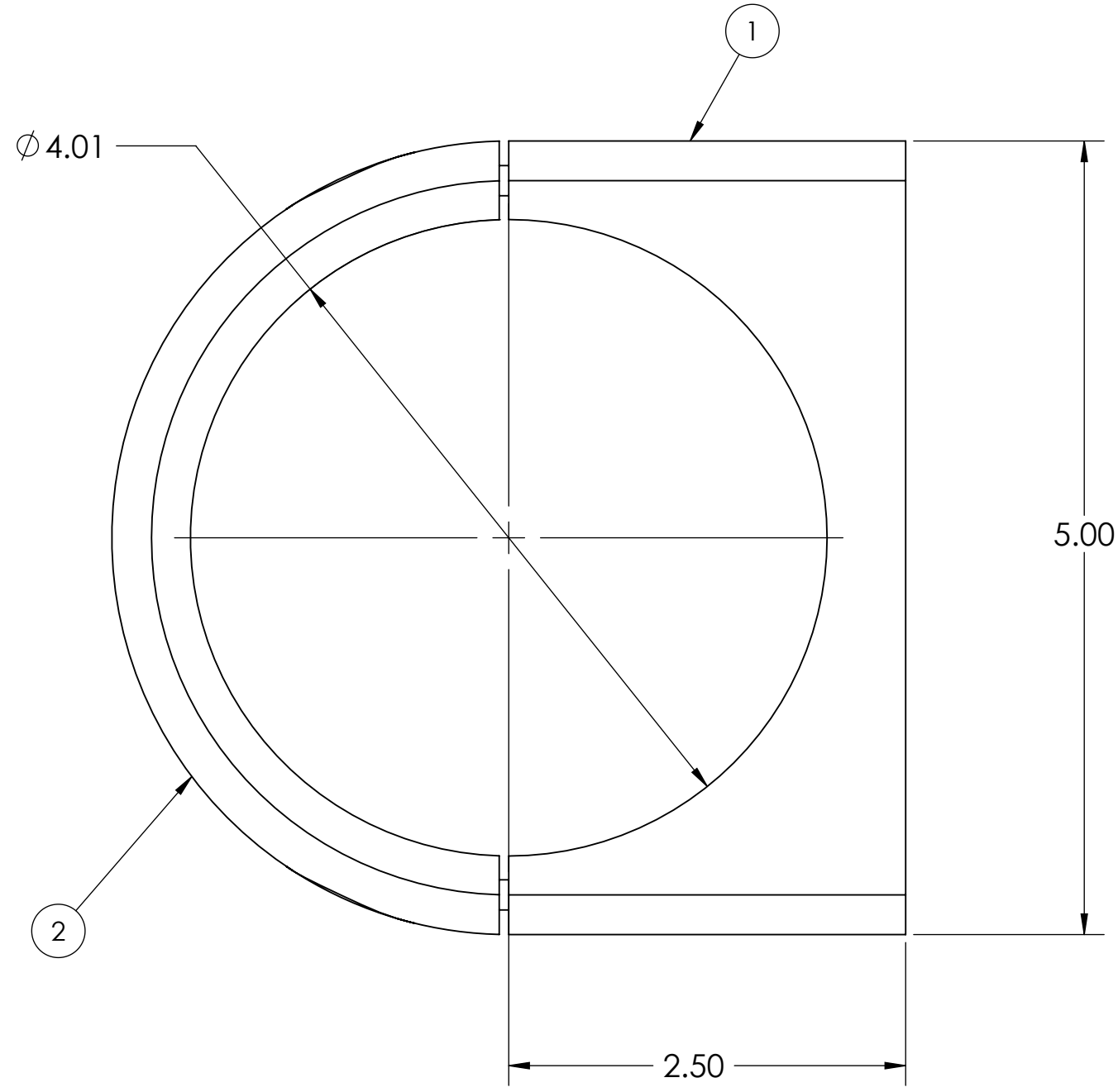
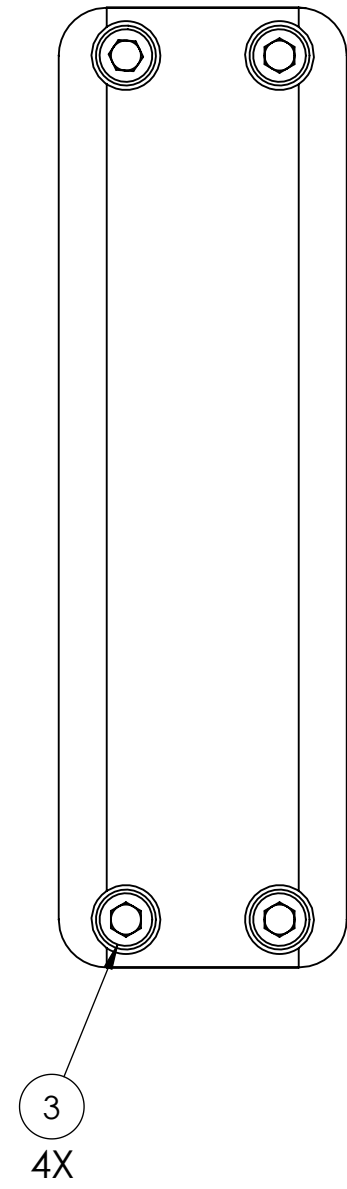

**ALL RIGHT RESERVED 2003-2005 ©, BLUEVIEW TECHNOLOGIES, INC**

THE INFORMATION CONTAINED IN THIS DRAWING IS THE SOLE PROPERTY OF BLUEVIEW TECHNOLOGIES.

UNLESS OTHERWISE SPECIFIED:		NAME	DATE	BLUEVIEW TECHNOLOGIES 3518 FREMONT AVENUE N SUITE 270 SEATTLE, WASHINGTON 98103	
DIMENSIONS ARE IN INCHES	DRAWN	DLAMB	8-22-06	TITLE: <b>SONAR CLAMP</b>	
TOLERANCES: ANGULAR: ± 2 TWO PLACE DECIMAL ± .01 THREE PLACE DECIMAL ± .005	CHECKED			SIZE	DWG. NO.
MATERIAL	ENG APPR.			<b>C</b>	<b>201392-00</b>
FINISH	MFG APPR.			SCALE: 1:2	WEIGHT:
DO NOT SCALE DRAWING	Q.A.			SHEET 1 OF 1	
	COMMENTS:				